



Allied knight[®]-kit SPAN MASTER

83 Y 258



ALLIED RADIO

C O R P O R A T I O N

100 N. WESTERN AVE. • CHICAGO 80, ILL.



TELEPHONE
HAYMARKET 1-6800

38K298
750156-19-AG-958

® Registered Trade-Mark of ALLIED RADIO CORP.

Entire Contents Copyrighted 1958 by ALLIED RADIO CORP.

INTRODUCTION

In a couple of evenings you can build the Span Master and hear thrilling foreign shortwave broadcasts from all over the world. The Span Master is a regenerative type receiver which covers regular programs on the standard broadcast band as well as short wave, including American and foreign broadcasts, amateur phone and code transmissions, ships-at-sea, and aircraft.

A convenient bandswitch gives you instant choice of any of 4 bands, providing continuous coverage from 540 kc to 30 mc. Calibrated electrical bandspread simplifies tuning the crowded shortwave bands. In keeping with the high quality of the components and circuit, the Span Master is transformer-powered and uses an efficient selenium rectifier.

The professional, contemporary styling of the cabinet makes this a receiver you'll be proud to display. The dials are clearly marked in white against black for added tuning ease. The panel is anodized aluminum.

SPECIFICATIONS

FREQUENCY RANGE:	Band A .54 - 1.7 mc Band B 1.65 - 5.0 mc Band C 4.5 - 14.5 mc Band D 13.5 - 30.0 mc
CONTROLS:	MAIN TUNING, BANDSPREAD, REGENERATION, FINE REG., VOLUME, BANDSWITCH, OFF-ON. PHONES-SPEAKER
TUBES:	6BZ6, detector; 6AW8A, audio amplifier and power amplifier.
POWER REQUIREMENT:	110-125 volts, 50-60 cycles AC. Consumes 10 watts.
SIZE:	6-3/4 x 13-11/16 x 6-3/16"

FEATURES

- CONTINUOUS COVERAGE .54 MC TO 30 MC
- BUILT-IN 4" PM SPEAKER
- HEADPHONES JACK AND SPEAKER CUTOFF SWITCH
- ELECTRICAL BANDSPREAD — SIMPLIFIES TUNING
- SEPARATE FINE REGENERATION CONTROL
- SMART PROFESSIONAL APPEARANCE

CHECKING YOUR KIT

Before starting to build this kit, check each part against the parts list on page 18. The wiring pictures in this book will help you identify the parts. Symbols used to give the value of the parts are: Ω for ohm, K for 1000, Meg for one-million, μ for micro or one-millionth, and fd for farad.

Keep the different sizes of screws and nuts separate, for convenience in building. The thinnest screws are #4 and the thickest are #10. The six that look like woodscrews are self-tapping screws.

CONSTRUCTION HINTS

The only tools necessary for building your Span Master are: A soldering iron rated about 100 watts, long-nose pliers, diagonal cutters and a screw-driver.

To mount a resistor or capacitor, pull the leads through the terminals so the part is tightly mounted. Then bend each lead around the terminal and cut off the excess wire, as shown in Figure 1.

The flexible tubing supplied with this kit is called "spaghetti". It is used to cover bare wires and leads where there is a chance they will touch other bare wires or the chassis. When spaghetti or bare wire are specified, cut a piece of the needed length.

Use only the color of wire specified in the instructions because the colored wires have been pre-cut to definite lengths.

HOW TO CARE FOR YOUR SOLDERING IRON

Your soldering iron is the key to good soldering since it supplies the essential ingredient — HEAT. If the tip is covered by a dirt (oxide) film, the iron will not be able to transfer its full heat. A new tip can be protected from film by coating it with solder the first time it is heated. An old tip should first be cleaned with a file until bare copper is exposed. Then solder-coat it like a new tip. Wiping the tip during use, with a clean cloth, will keep the tip clean and shiny.

Never use the iron like a brush — soldering is not a paste-spreading operation. To get the most heat out of the iron, always press the iron firmly to the connection. Hold it so the greatest tip surface is directly in contact with the connection.

THIS KIT MUST BE PROPERLY SOLDERED!

WITHOUT GOOD SOLDERING, AN ELECTRONIC UNIT WILL NOT WORK . . . just as a suit of clothing will fall apart if the stitches are loose . . . no matter how excellent the material.

USE ENOUGH HEAT

This is the main idea of good soldering. The purpose of soldering is to join metal parts, making an UNBROKEN metal path over which electricity can travel. To do this you must apply enough heat to the metal surfaces to make the solder spread freely on them, until the contour (shape) of the connection shows under the solder. If the solder barely melts and forms a rounded ball, *you are not using enough heat*. If you do not use enough heat, there may be no electrical connection, although it appears soldered.

HERE'S HOW TO DO IT . . .

1. Join bare metal to bare metal. Insulation must be removed.
2. Coat the tip of a hot iron with solder.
3. **FIRMLY PRESS THE FLAT SIDE OF THE TIP OF A HOT IRON FLAT** against the parts to be soldered together. Keep it there while you apply the solder **BETWEEN THE IRON TIP AND THE METAL TO BE SOLDERED**. Use only enough solder for it to flow over **ALL** the surfaces of the connection. Remove the iron.
4. **DO NOT MOVE PARTS UNTIL THE SOLDER HARDENS**. If you accidentally move the wires as the solder is hardening, apply your iron and reheat.

Compare your soldering with the pictures on this page. You have a good connection if your solder has flowed over all surfaces to be connected, following the shape of the surfaces. It should appear smooth and bright.

YOU HAVE NOT USED ENOUGH HEAT: If your connection is rough and flaky-looking, or if the solder has formed a round ball instead of spreading.

The difference between good soldering (enough heat) and poor soldering (not enough heat,) is just a few extra seconds with a hot iron **FIRMLY** applied. Remember, larger metal surfaces take a longer time to heat.

USE A 100-WATT IRON

A 100-watt soldering iron with a clean, chisel-shaped tip will supply the right amount of heat when used correctly. Notice how the iron is held in the picture. Heat the iron for 10 minutes before you start soldering. Keep the tip brightly coated with solder. When necessary, wipe the hot tip clean with a cloth. (If you use a soldering gun, be sure the tip reaches full heat before you solder.)

USE ONLY ROSIN CORE SOLDER

We supply the right kind of solder (*rosin core solder*). Do not use any other kind of solder! **USE OF ACID CORE SOLDER, PASTE, OR IRONS CLEANED ON A SAL AMMONIAC BLOCK WILL RUIN ANY ELECTRONIC UNIT AND WILL VOID THE GUARANTEE.**

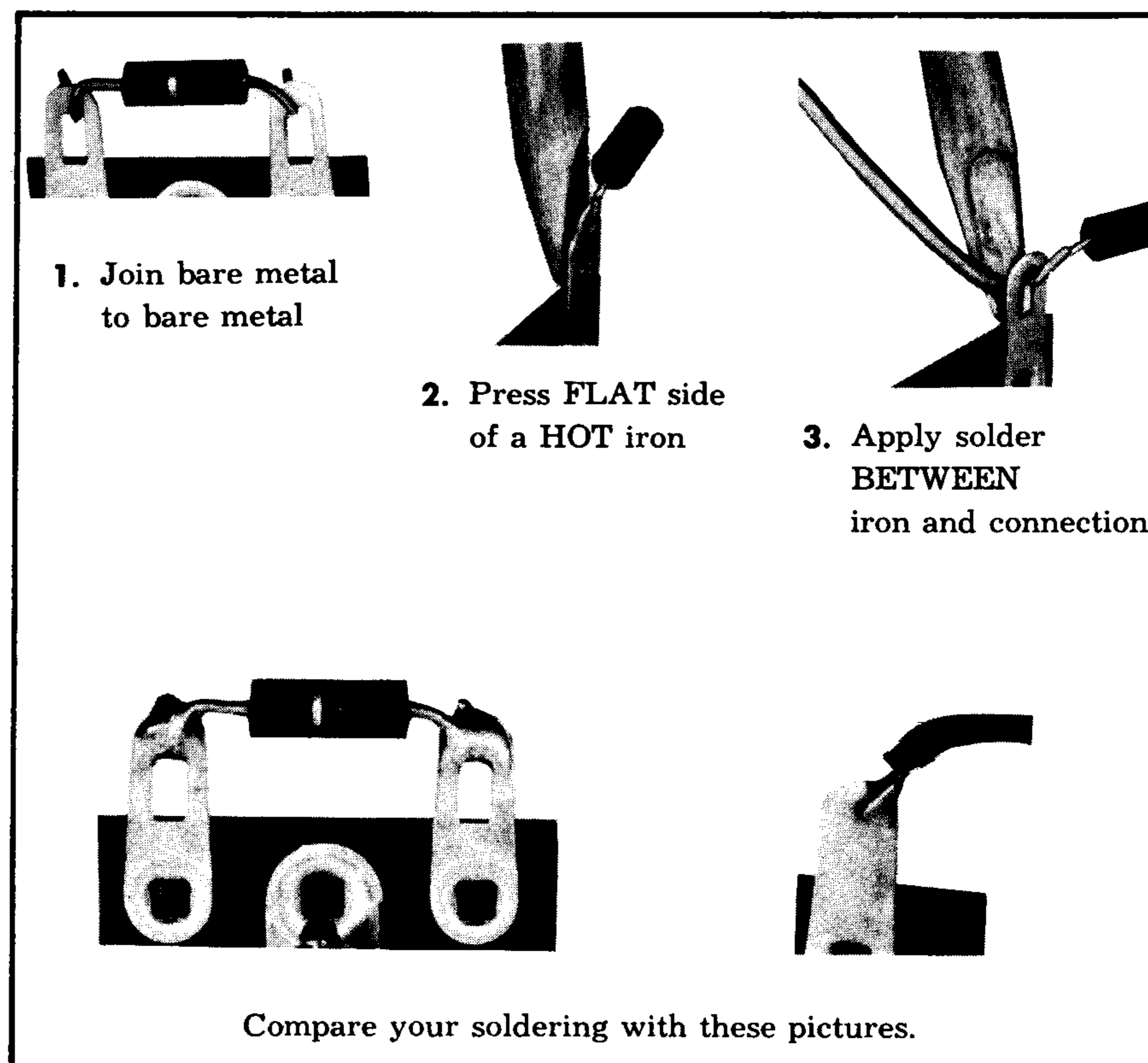

FIGURE 1. THE ONE-TWO-THREE OF GOOD SOLDERING

FIRST PARTS MOUNTING AND WIRING

SEE FIGURE 3.

The panel and perforated grille are attached to the chassis at the same time the S-1, R-3, R-10 and R-2 controls are mounted. Partially remove protective tape so that area around holes is free.

- Mount S-1, the BAND SWITCH, as shown in Figure 2. Position the color dot as shown in Figure 3. Notice that first a lockwasher is slipped over the shaft of S-1. Then the shaft is pushed through the chassis and the panel. From outside the panel, a flat washer and nut are slipped on the shaft and tightened.

AS SHOWN IN FIGURE 2:

- Mount R-3, the 50K Ω REGENERATION control.
- Mount R-10, the 1 meg Ω VOLUME control with the S-3 OFF-ON switch attached.
- Mount R-2, the 10K Ω FINE REG. control.

THESE PARTS MUST BE MOUNTED FROM INSIDE THE CHASSIS:

- Mount the 7-pin tube socket, V-1, and a solder lug. Use two 6-32 x 5/16" screws, one lockwasher and two nuts. The keyway (extra space between two pins) must be positioned as shown. Position the solder lug so it leans against pin 3.
- Mount the 9-pin tube socket, V-2, and a solder lug. Position the keyway as shown. Use two 6-32 x 5/16" screws, one lockwasher and two nuts.
- Insert three large rubber grommets on the bottom of the chassis, and one on the rear of the chassis, as shown.
- Mount TS-2, the 6-terminal strip. Use a 6-32 x 5/16" screw, lockwasher and nut. Position the terminals as shown.

Note: TS-4 and TS-3 are 2-terminal strips. Both have the mounting foot to the left of the other terminal.

- Mount TS-4 with a 6-32 x 5/16" screw, lockwasher and nut.
- Mount TS-3 and CR-1, the selenium rectifier. Use one 6-32 x 5/16" screw, lockwasher and nut. Position the terminals as shown.
- Mount S-2, the slide switch, on the rear of the chassis, using the two short, thin screws (#4-36), lockwashers and nuts. S-2 should be positioned so the side with the 2 terminals is next to the grommet.
- Mount J-1, the PHONES jack. Use two 6-32 x 5/16" screws, lockwashers and nuts.
- From OUTSIDE the rear of the chassis, mount TS-5, the strip with two screw terminals, and a solder lug. Use two 6-32 x 5/16" screws, a lockwasher and two nuts. Position the solder lug against terminal 2 of TS-5.

- Turn the chassis over. Position L-6, the filter choke, on top of the chassis, as shown in Figure 11, with the two leads inserted through the nearest grommet. Mount with two 6-32 x 5/16" screws. From the inside of the chassis, use the screw nearest R-2 to mount TS-1, the remaining 2-terminal strip. Secure with two lockwashers and nuts.
- From top of the chassis, mount T-1, the power transformer, so that the two black leads go through the grommet nearest S-2, and the other four leads go through the center grommet, as shown in Figure 11. Insert two 6-32 x 5/16" screws and turn the chassis over.
- From inside the chassis, slip a lockwasher and nut on one of these screws (the one nearest the edge). On the other screw used to mount T-1, mount C-17, the 30-30-20 μ fd tubular capacitor, a solder lug and a nut. Bend mounting foot of C-7 as needed. C-17 must be positioned so the end with one wire is closest to S-2. Tighten both nuts.

□ STUDY THE HOW TO SOLDER INSTRUCTIONS ON PAGE 3

Note: Choke and transformer leads should be shortened wherever necessary for neat wiring. After shortening the wire, remove 1/4" of the insulation from the end of the wire. Twist the stranded ends tightly and coat lightly with solder.

- Connect, but do not solder, one of the L-6 leads to terminal 6 of TS-2. Connect, but do not solder, the other lead to terminal 1 of CR-1.
 - Solder one of the red leads from T-1 to terminal 2 of CR-1. Connect, but do not solder the other red lead to terminal 1 of TS-3.
 - Connect, but do not solder, one of the green leads from T-1 to pin 5 of V-2. Solder the other green lead to terminal 1 of TS-3 (2 wires).
- Note: (2 wires) means there are 2 wires in the terminal and BOTH must be soldered to the terminal.
- Solder one of the black leads from T-1 to terminal 1 of S-3. Connect, but do not solder, the other black lead to terminal 2 of TS-3.
 - Connect, but do not solder, the black lead from C-17 to terminal 1 of TS-1.
 - Solder one of the red leads from C-17 to terminal 1 of CR-1 (2 wires). Route the other red lead as shown and connect, but do not solder, it to terminal 6 of TS-2.
 - Connect, but do not solder, the blue lead from C-17 to pin 6 of V-2.

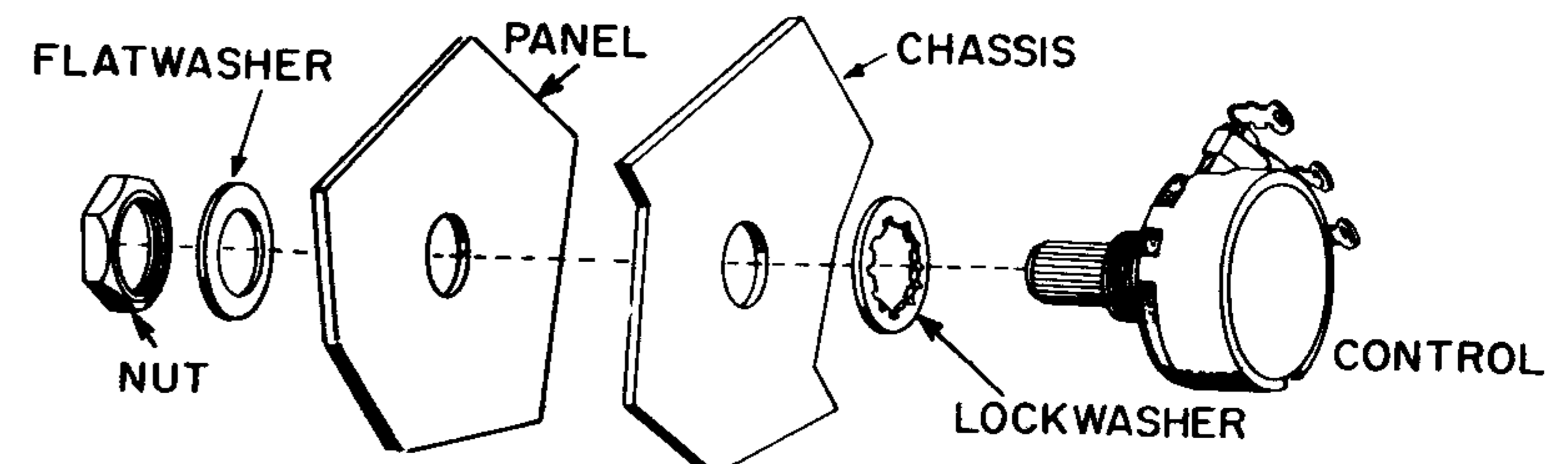

FIGURE 2. HOW TO MOUNT A CONTROL

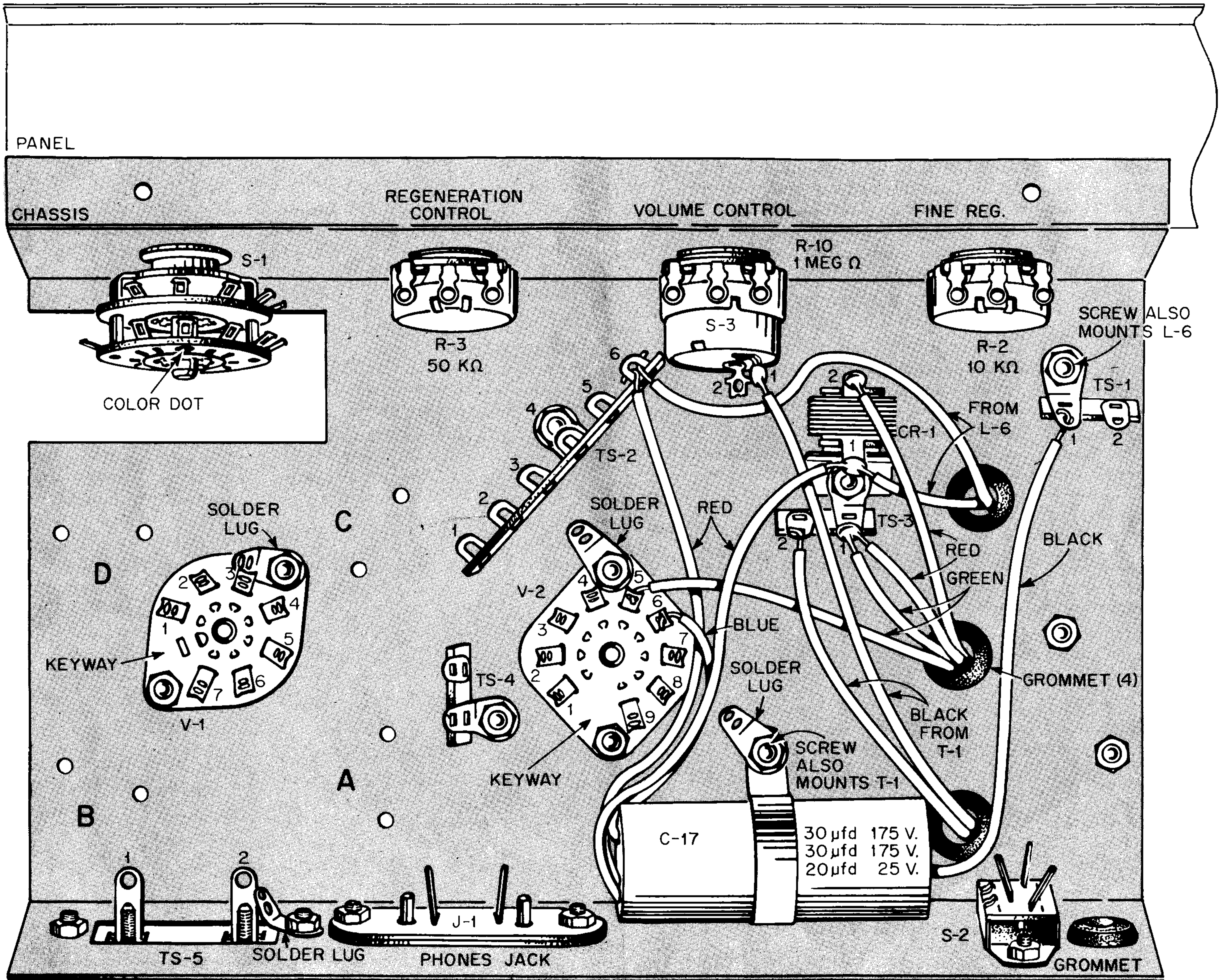

FIGURE 3. FIRST PARTS MOUNTING AND WIRING VIEW

SECOND PARTS MOUNTING AND WIRING

SEE FIGURE 5.

- Connect, but do not solder, one lead of R-9, a 3.3K Ω resistor (marked with color bands orange, orange, red) to pin 1 of V-2. Thread the other lead through pin 4 and solder it to the solder lug near pin 4.
- Connect, but do not solder, the lead from the negative end (—) of C-13, a 10 μ fd tubular capacitor, to terminal 2 of J-1. Solder the lead from the positive (+) end to pin 1 of V-2 (2 wires). **THESE LEADS MUST NOT BE REVERSED.**
- Solder one end of a red wire to terminal 2 of J-1. (2 wires). Connect, but do not solder, the other end to terminal 1 of TS-4.
- Connect, but do not solder, one lead of R-8, a 470K Ω resistor (yellow, violet, yellow) to terminal 1 of TS-4. Connect, but do not solder, the other lead to pin 2 of V-2.
- Cut the 8" shielded cable in half. Prepare both pieces by removing insulation and attaching bare wire as shown in the detail under Figure 5. Put one aside for later use.
- Connect, but do not solder, the bare wire wrapped around one of the shielded cables to the solder lug at C-17. Connect, but do not solder, the inner conductor at the same end of the cable to pin 9 of V-2. Solder the other end of the inner conductor to terminal 2 of S-2.
- Connect, but do not solder, one end of a green wire to pin 8 of V-2. Connect, but do not solder, the other end to terminal 2 of TS-1.
- Slip 1-3/8" of spaghetti on each lead of R-13, a 1500 Ω (brown, green, red) resistor. Solder one lead to terminal 3 of S-2. Connect, but do not solder, the other lead to terminal 2 of TS-1.
- Connect, but do not solder, one end of a blue wire to terminal 2 of TS-4. Connect, but do not solder, the other end to terminal 1 of R-2.
- Solder one end of an orange wire to pin 4 of V-1. Solder the other end to pin 5 of V-2 (2 wires).
- Solder one end of a 1-3/4" thin bare wire to pin 2 of V-1. Thread the other end through pin 3, and connect, but do not solder, it to pin 7 of V-1.
- Connect, but do not solder, one end of a yellow wire to pin 5 of V-1. Connect, but do not solder, the other end to terminal 5 of TS-2.
- Solder one lead of C-5, a .001 μ fd disc capacitor (may be marked 1000 or 1K) to pin 3 of V-1. (2 wires). At the same time, solder pin 3 and the solder lug together. Solder the other lead of C-5 to pin 5 of V-1 (2 wires).
- Connect, but do not solder, one lead of R-1, a 2.2 meg Ω resistor (red, red, green) to pin 1 of V-1. Connect, but do not solder, the other lead to pin 7 of V-1.
- Solder one lead of C-6, a 15 μ fd disc capacitor, to pin 7 of V-1 (3 wires). Connect, but do not solder, the other lead to pin 6 of V-1.

- Connect, but do not solder, one lead of L-5, the RF choke, to pin 6 of V-1. Solder the other lead to terminal 2 of TS-4 (2 wires).
- Connect, but do not solder, one lead of R-5, a 10K Ω resistor (brown, black, orange) to terminal 2 of TS-2. Connect, but do not solder, the other lead to terminal 3 of TS-2.
- Connect, but do not solder, one lead of R-6, an 18K Ω resistor (brown, gray, orange) to terminal 3 of TS-2. Connect, but do not solder, the other lead to terminal 5 of TS-2.
- Slip 1-3/4" of spaghetti on the lead from the positive (+) end of C-9, the 8 μ fd tubular capacitor. Spaghetti must be close to the body of C-9. Solder this lead to terminal 3 of TS-2 (3 wires). Connect, but do not solder, the other lead (may be marked —) or negative) to terminal 1 of TS-1.
- Solder one end of an orange wire to terminal 4 of TS-2. Connect, but do not solder, the other end to terminal 1 of R-3.
- Solder one end of an orange wire to terminal 1 of R-3 (2 wires). Solder the other end to terminal 1 of R-10.
- Solder one end of a green wire to terminal 2 of R-3. Solder the other end to terminal 3 of R-2.
- Use matching nuts and lockwashers to mount the L-1, L-2, L-3 and L-4 coils, as shown in Figure 4. The letter stamped on the side of the coil must face the matching letter stamped on the chassis as shown. For example, L-1 should be mounted so the "A" on the coil faces the "A" on the chassis.

IMPORTANT NOTICE! THIS RECEIVER WILL NOT WORK CORRECTLY IF COILS ARE INTERMIXED.

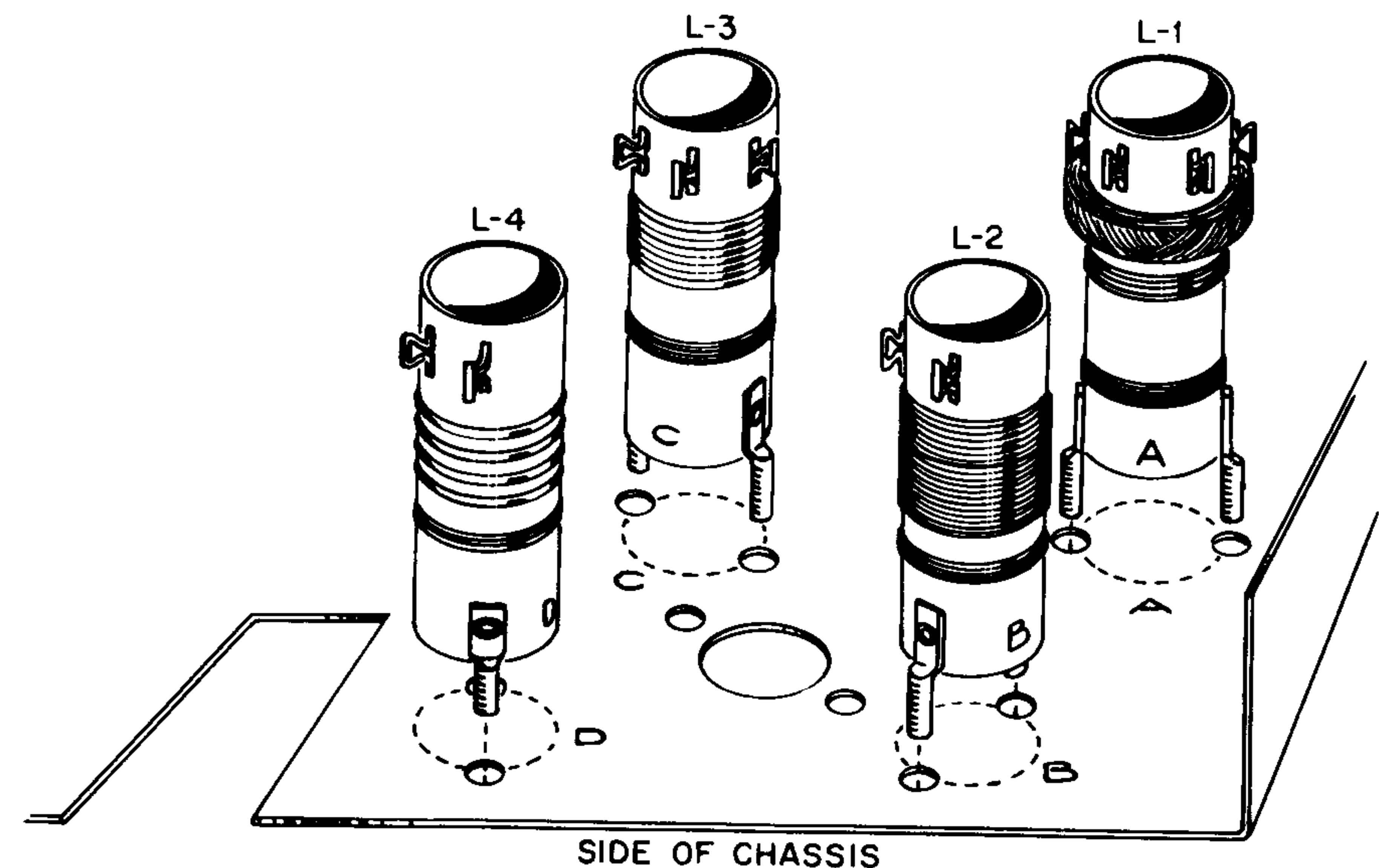

FIGURE 4. HOW TO MOUNT THE COILS

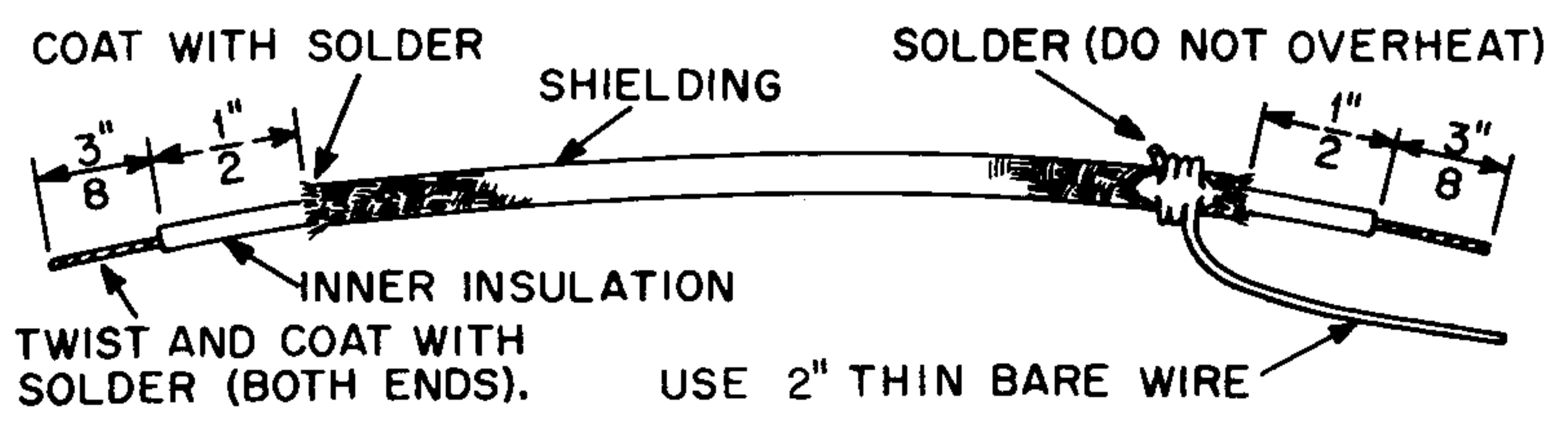
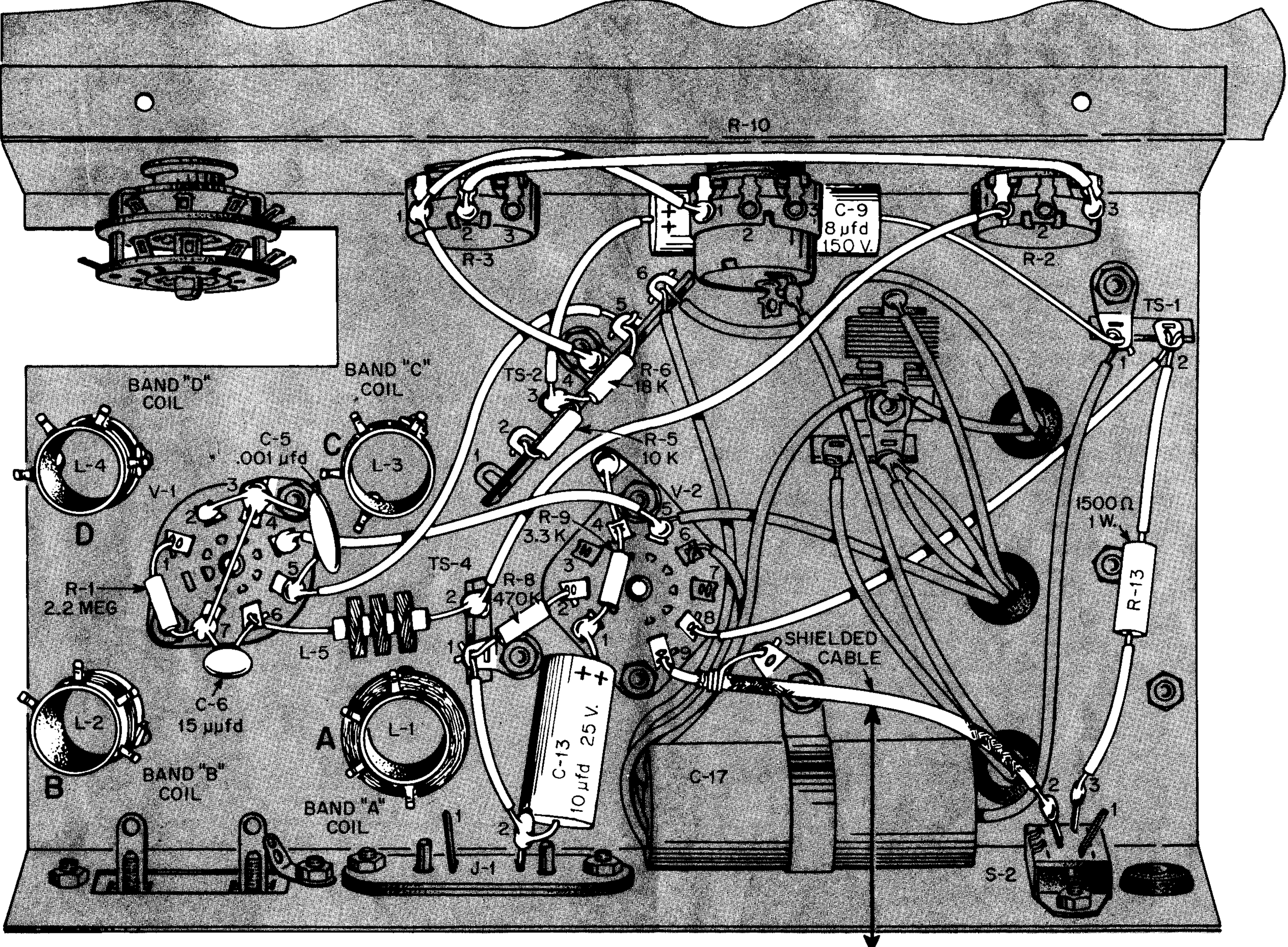

FIGURE 5. SECOND PARTS MOUNTING AND WIRING VIEW

THIRD WIRING

SEE FIGURES 6 AND 7.

For correct operation of this receiver, all wires connected to the S-1 switch must be as short as possible. For ease in wiring, twist the ends of the stranded wires and coat lightly with solder. Figure 6 shows the switch as seen from the top of the chassis since these terminals are most easily soldered from the top of the chassis.

When wiring to switch terminals, keep wire away from other terminals. **DO NOT BEND TERMINALS.**

- FROM THE TOP OF THE CHASSIS:** Solder one end of a 2-1/2" white-green wire to terminal 16 of S-1. Solder the other end to terminal 2 of L-4 on the underside of the chassis.
- Solder one end of a 2-1/4" white-yellow wire to terminal 17 of S-1. Solder the other end to terminal 4 of L-3.
- Solder one end of a 4-1/8" white-black wire to terminal 18 of S-1. Route as shown in Figure 7. Solder the other end to terminal 1 of L-2.
- Solder one end of a 4-1/4" white-red wire to terminal 19 of S-1. Solder the other end to terminal 4 of L-1.
- Slip 1-1/4" of spaghetti on each lead of C-7, a .001 μ fd (1K or 1000) disc capacitor. Solder one lead to terminal 20 of S-1. Solder the other lead to pin 6 of V-1 (3 wires).
- Solder one end of a 2-1/2" white-green wire to terminal 6 of S-1. Solder the other end to terminal 4 of L-4.
- Solder one end of a 2-1/4" white-yellow wire to terminal 7 of S-1. Solder the other end to terminal 3 of L-3.
- Solder one end of a 4-1/8" white-black wire to terminal 8 of S-1. Solder the other end to terminal 4 of L-2.
- Solder one end of a 4-1/4" white-red wire to terminal 9 of S-1. Solder the other end to terminal 3 of L-1.
- Solder one end of a green wire to terminal 10 of S-1. Solder the other end to terminal 1 of TS-5.
- Slip 3/4" of spaghetti on each lead of R-4, a 22K Ω (red, red, orange) resistor. Solder one lead to terminal 3 of R-3. Connect, but do not solder, the other lead to terminal 6 of TS-2.
- Solder one end of a red wire to terminal 6 of TS-2 (4 wires). Connect, but do not solder, the other end to terminal 2 of TS-2.
- Connect, but do not solder, one end of a red wire to terminal 2 of TS-2. Solder the other end to pin 8 of V-2 (2 wires).
- Solder one lead of R-11, a 47K Ω (yellow, violet, orange) resistor, to terminal 2 of TS-2 (4 wires). Connect, but do not solder, the other lead to pin 3 of V-2.
- Slip 3/4" of spaghetti on each lead of C-10, a .005 μ fd (5K or 5000) disc capacitor. Solder one lead to terminal 5 of TS-2 (3 wires). Connect, but do not solder, the other lead to terminal 1 of TS-2.

- Connect, but do not solder, one lead of R-7, a 100K Ω (brown, black, yellow) resistor to pin 2 of V-2. Solder the other lead to terminal 1 of TS-2 (2 wires).
- Solder one lead of C-11, a 330 μ fd disc capacitor, to pin 2 of V-2 (3 wires). Solder the other lead to terminal 1 of TS-4 (3 wires).
- Slip 3/4" of spaghetti on each lead of C-16, a .02 μ fd (20K or 20,000) disc capacitor. Connect, but do not solder, one lead to pin 9 of V-2. Solder the other lead to terminal 1 of J-1. **BE CAREFUL TO AVOID DAMAGING COIL L-1.**
- Connect, but do not solder, one lead of C-15, a 330 μ fd disc capacitor, to pin 6 of V-2. Solder the other lead to pin 9 of V-2 (3 wires).
- Connect, but do not solder one lead of R-12, a 270 Ω (red, violet, brown) 1-watt resistor, to the solder lug at C-17. Solder the other lead to pin 6 of V-2 (3 wires).
- Insert the bare ends of the line cord through the grommet on the rear of the chassis. Knot the cord about 5-1/2" from the ends. Cut 1" from one of the line cord wires. Remove 1/4" of the insulation from the end of this wire; twist the stranded ends together and coat lightly with solder. Solder this wire to terminal 2 of TS-3 (2 wires). Solder the other line cord wire to terminal 2 of S-3.

CAUTION: DO NOT PLUG LINE CORD INTO POWER OUTLET AT THIS TIME!

- Solder the lead from the banded end of C-8, the .1 μ fd tubular capacitor, to terminal 1 of TS-1. (3 wires). Thread the other lead through terminal 2 of R-2 and solder it to terminal 1 of R-2 (2 wires). Solder terminal 2 of R-2.

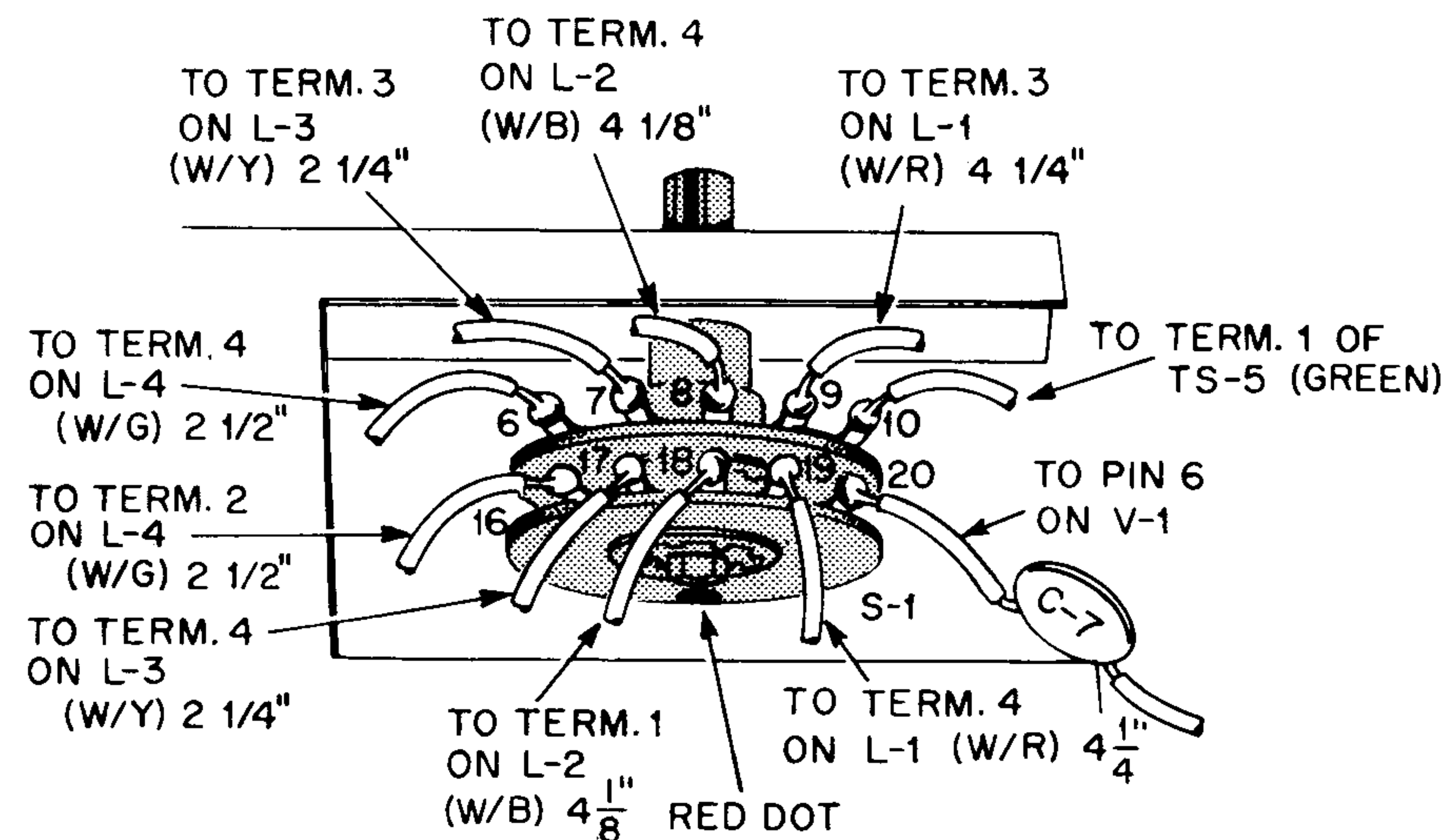

WIRE COLORS: White-green (W/G); White-yellow (W/Y); White-black (W/B); White-red (W/R).

FIGURE 6. BAND SWITCH WIRING DETAIL

SEE DETAIL
FOR S-1 WIRING

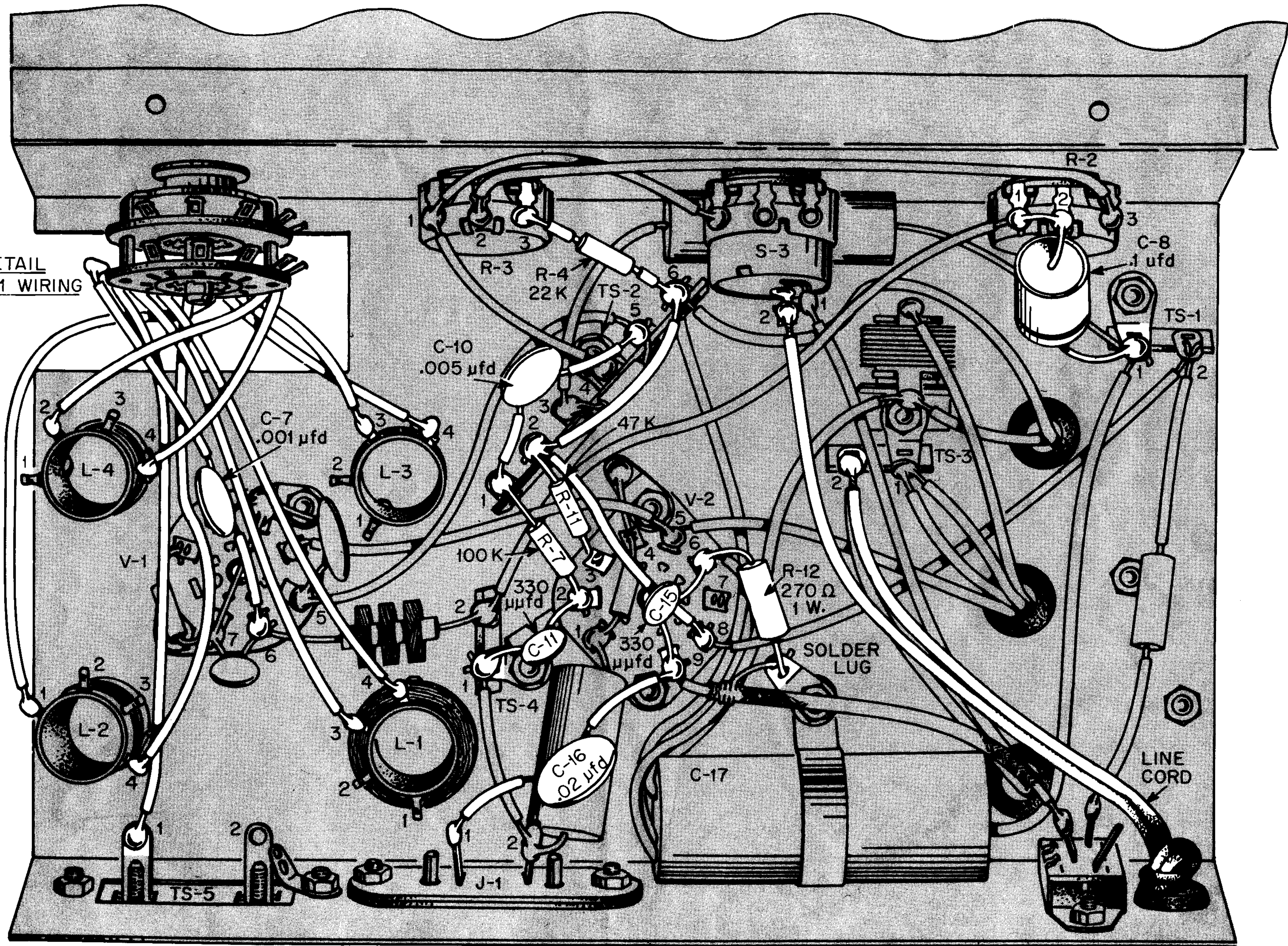

FIGURE 7. THIRD WIRING VIEW

FOURTH WIRING

SEE FIGURE 8.

- Connect, but do not solder, one end of 1-3/4" thin bare wire to terminal 15 of S-1. Route as shown, and solder it to terminals 2, 3 and 4 of S-1. **TERMINAL 5 of S-1 IS NOT CONNECTED AT THIS TIME!**
 - Slip the required length of spaghetti on each lead of C-4, a 100 $\mu\mu\text{fd}$ mica capacitor so the shortened leads are covered. Solder one lead to terminal 15 of S-1 (2 wires). Solder the other lead to pin 1 of V-1 (2 wires).
- Note: All wires and leads connected to S-1 must be as short as possible.
- Solder one end of a 4-1/4" white-red wire to terminal 14 of S-1. Solder the other end to terminal 2 of L-1.
 - Solder one end of a 3-1/2" white-black wire to terminal 13 of S-1. Solder the other end to terminal 3 of L-2.
 - Solder one end of a 2-1/4" white-yellow wire to terminal 12 of S-1. Solder the other end to terminal 2 of L-3.
 - Connect, but do not solder, one lead of C-3, a 450 $\mu\mu\text{fd}$ mica capacitor, to terminal 11 of S-1. Solder the other lead to terminal 1 of S-1.
 - Slip 3/4" of spaghetti on a 1-1/4" bare wire. Solder one end to terminal 11 of S-1 (2 wires). Solder the other end to terminal 3 of L-4.
 - Connect, but do not solder, one lead of C-12, a 330 $\mu\mu\text{fd}$ disc capacitor, to pin 3 of V-2. Solder the other lead to pin 4 of V-2 (2 wires).
 - Slip 1-1/2" of spaghetti on each lead of C-14, a .005 μfd (5K or 5000) disc capacitor. Solder one lead to pin 3 of V-2 (3 wires). Solder the other lead to terminal 3 of R-10.

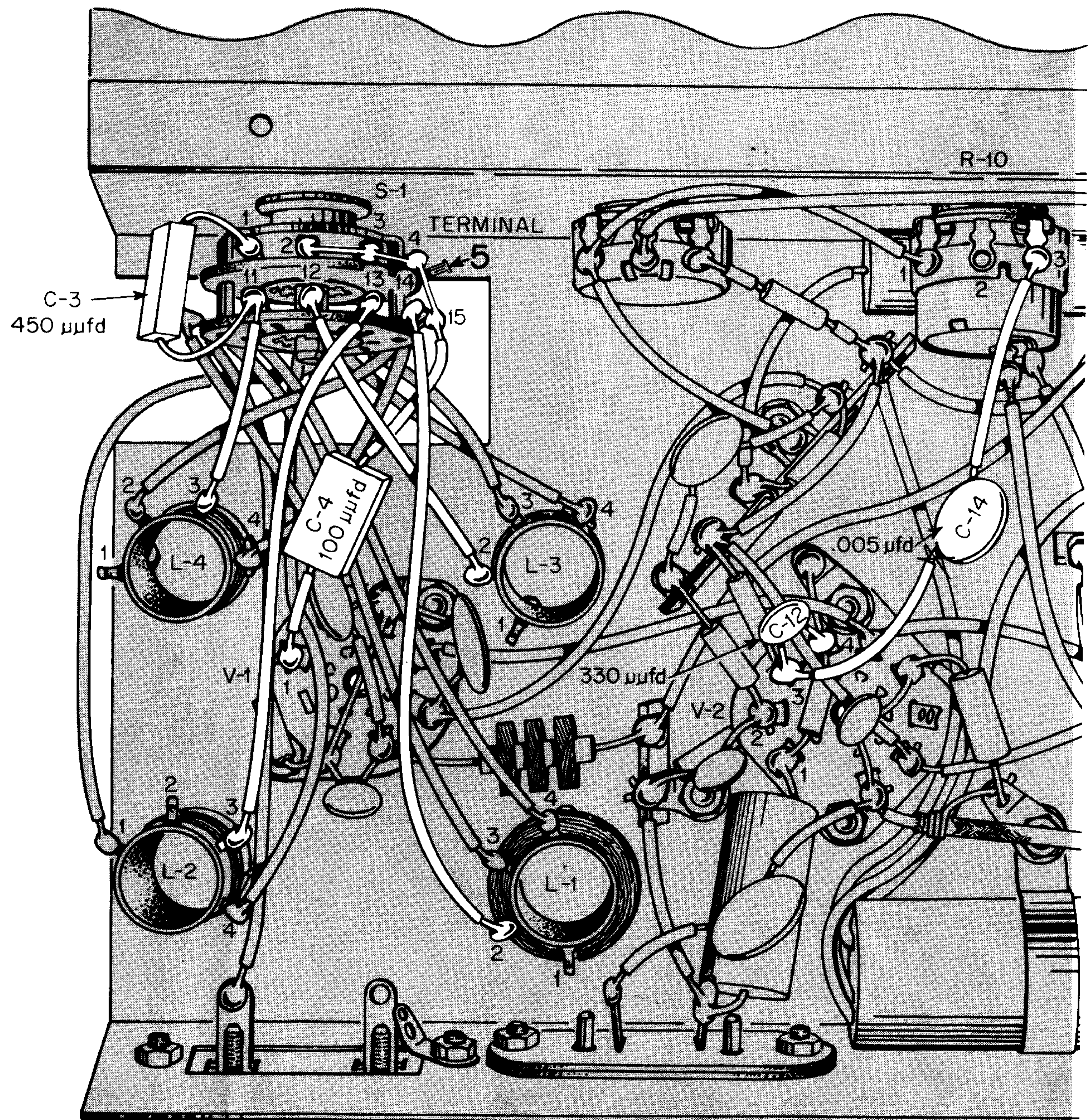

FIGURE 8. FOURTH WIRING VIEW

FIFTH WIRING

SEE FIGURE 9.

- Mount the speaker on its bracket: Insert 6-32 x 5/16" screws through 2 holes in the speaker frame. Slip a small grommet on each screw. Attach the bracket and fasten with lockwashers, and nuts. **DO NOT DAMAGE THE PAPER SPEAKER CONE.**
- Attach the Tinnerman bracket to the back of the chassis. Use a 6-32 x 5/16" screw, lockwasher and nut.
- Slip 2" of spaghetti on a 2-1/2" bare wire. Solder one end to terminal 5 of S-1. Push the other end through the cutout in the chassis. It will be connected later.
- Form a right-angle bend 4" from one end of a 10" heavy bare wire. Push the long end of this wire through the cutout. It will be connected

later. Solder the short end of the wire to terminal 2 of TS-5. At the same time, solder terminal 2 to the solder lug at TS-5. **Extra heat is needed for this connection.**

- Solder one end of a 1-3/4" thin bare wire to terminal 1 of L-4. Solder the other end to terminal 2 of L-2.
- Solder one end of a 2-3/4" thin bare wire to terminal 1 of L-3. Route as shown. Solder it to the heavy wire. Solder the other end to the thin bare wire between L-4 and L-2.
- Solder one end of a 1-1/2" thin bare wire to terminal 1 of L-1. Solder the other end to the heavy bare wire.
- Solder the bare wire wrapped around the remaining shielded cable to the solder lug at C-17 (3 wires). Solder the inner conductor of this end of the cable to pin 7 of V-2. Solder the other end of the inner conductor to terminal 2 of R-10.
- Solder the blue lead from the speaker assembly to terminal 2 of TS-1 (3 wires). Solder the red lead to terminal 1 of S-2.

now be soldered. If in doubt about a solder connection, apply a hot iron to it until the solder flows over all wires in the terminal.

BARE WIRES AND BARE LEADS NOT CONNECTED TO THE SAME TERMINAL MUST NOT ACCIDENTALLY TOUCH EACH OTHER OR THE CHASSIS.

FINAL ASSEMBLY

SEE FIGURE 10. HOW TO ASSEMBLE THE DIALS.

- Be sure the plates of C-1 and C-2 are completely closed.
- Slip a dial plate over the shaft of C-2. Attach with 2 self-tapping **FLATHEAD** screws. Drive the screws into the panel until the heads are flush with the dial plate.

made on the dial plate. Smooth the dial in place.

- Push the knob on the shaft. The hairline should line up with the 0 and 10. If the knob is loose, use your screwdriver to slightly spread apart the split shaft.
- Assemble the Main Tuning Dial in the same way, except that the dial must be positioned so the hairline when horizontal covers letters D, A, B and C on the dial.
- Remove the protective tape from the panel.
- Push the small knob with the flat-sided hole on the shaft of the **BAND SWITCH**.
- Turn the shafts of the **REGENERATION**, **OFF-VOLUME** and **FINE REG.** controls all the way to the left. Push knobs on, so the white line on each points to about a 7 o'clock position.
- Insert the V-1, 6BZ6 tube and the V-2, 6AW8A tube in their sockets, as indicated in Figure 11.

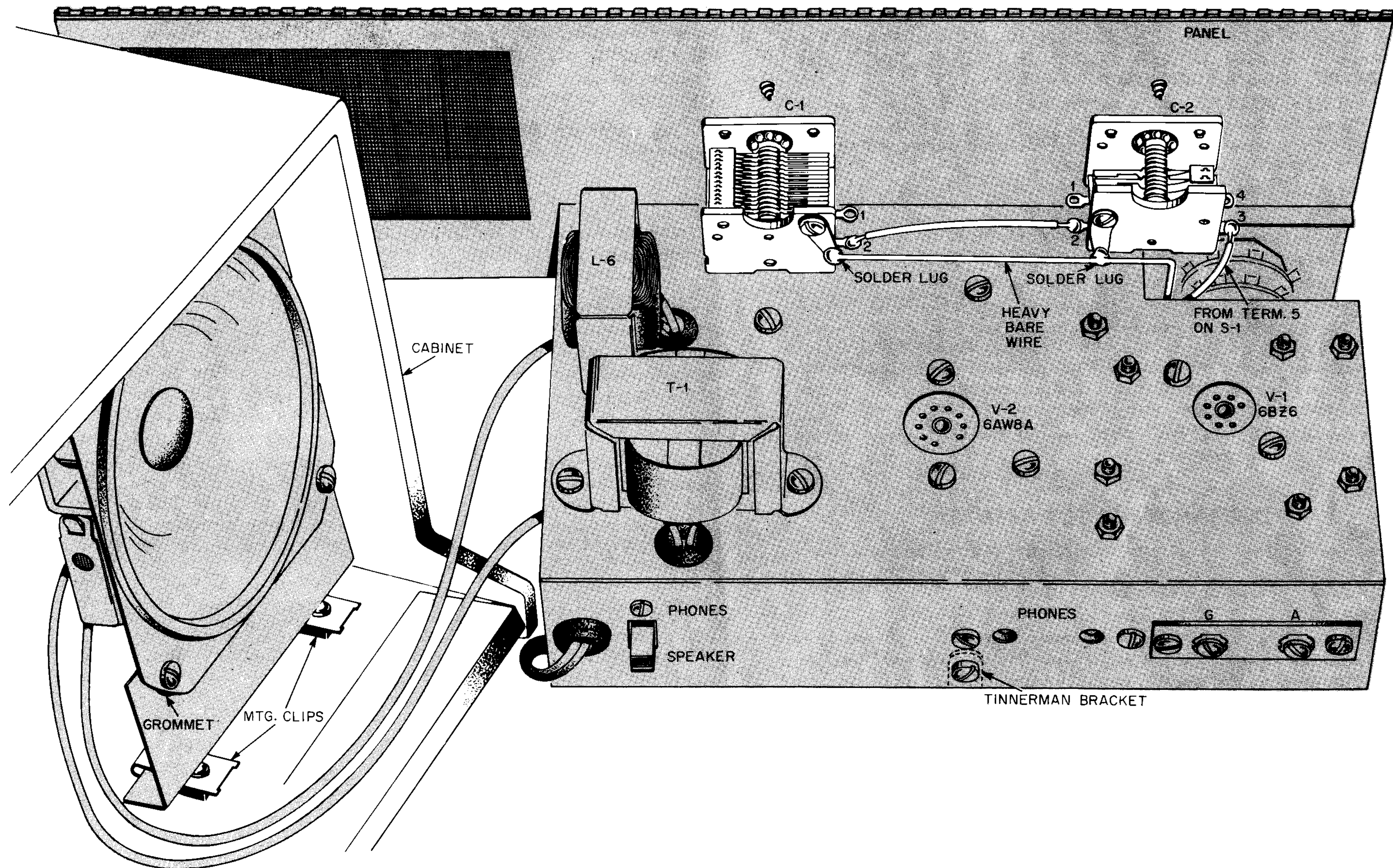

FIGURE 11. FINAL WIRING

PRELIMINARY TEST

- Temporarily install the receiver in the cabinet. The line cord should come through the rear cutout.
- Set the SPEAKER-PHONES switch on the back panel to SPEAKER.
- Plug the line cord into an outlet supplying 110-125 volts, 50-60 cycles AC only. CAUTION: DO NOT TOUCH THE WIRING WHEN THE LINE CORD IS CONNECTED TO A POWER OUTLET.
- Turn the OFF-VOLUME switch on (to the right). The tubes should light. Turn the REGENERATION control all the way to the right. You will hear a whistle. If the whistle is too loud, reduce the volume by turning the VOLUME control to the left.
- Turn the Main Tuning dial (marked for Bands D, A, B and C) through its entire range. The whistle should continue.
- Repeat the last step with the BAND SWITCH in each of its 4 positions. The receiver is ready for permanent installation. Turn the set OFF.

If the tubes fail to light, or you do not hear a whistle on all bands when the REGENERATION control is turned up, see the SERVICING HINTS.

- Secure the receiver in the cabinet by inserting the 8-32 screw through the bottom of the cabinet and into the Tinnerman bracket at the rear of the chassis. Insert the two roundhead self-tapping screws through the other two holes in the bottom of the cabinet and through the two matching holes in the bottom edge of the chassis. Tighten the screws.
- Apply the KNIGHT-KIT "K" decal on the panel, as shown in the photograph on the cover page.

UNDERSTANDING YOUR RECEIVER

As you develop skill in operating your Span Master, you will learn how to bring in stations from amazing distances. Understanding your receiver helps you develop the necessary skill.

THE ANTENNA:

The antenna brings into the receiver signals covering all bands. The better the antenna, the stronger the signal fed the receiver, and the greater the number of stations that can be received. Figure 11 shows how to install a good antenna.

TUNING:

Since the antenna brings in all signals within its range, the receiver must select the desired station and reject all others. This is done by the tuning section, which consists of the Band Coils, L-1, L-2, L-3, L-4 and the Tuning Capacitors C-1 plus C-2.

BANDSWITCHING:

The station selected (tuned in) changes every time the setting of the capacitor changes or a different coil is selected. You can tell the coils have different electrical values by the number of turns of wire. Band A coil has the most turns and is used to tune in stations on the lower frequencies. Band D has the fewest turns and is used for the highest frequencies. The BAND SWITCH S-1, selects the desired band coil.

MAIN TUNING AND BANDSPREAD:

After the BAND SWITCH selects the desired band coil, you can tune the exact station you want by adjusting the tuning capacitors. The electrical value of the capacitors changes as you open or close the plates. Main Tuning is done with C-1, because a big change of capacity results from opening or closing the plates just a little. Fine tuning is done with C-2, called the BANDSPREAD.

DETECTION:

Only part of the station's signal contains the desired program (music, sound, etc.). This part rides on a carrier wave used to carry the program far greater distances than the audio (sound) signal could otherwise travel. Once the signal is received the part of the signal which conveys the program must be separated from the carrier and then amplified (enlarged). In V-1, the 6BZ6 tube, the carrier wave is removed and the desired portion of the signal is DETECTED.

REGENERATION:

This feature of your receiver allows you to receive even very weak signals. It is like a controlled snowballing action, getting bigger and bigger, until the desired signal strength is reached. Uncontrolled regeneration would drown out the program you want. Too little would make it too weak.

Regeneration takes place in the V-1 6BZ6 tube circuit, with the signal amplified in the tube. It is taken off the screen (pin 6) and fed back to the grid (pin 1) of the same tube through the feedback circuit of C-7, S-1, the BAND coil and C-4. The amount of feedback or regeneration is controlled by REGENERATION and FINE REG. (REGeneration) controls. These controls act by raising or lowering the screen voltage.

The REGENERATION control is always used first to give the approximate amount you want. FINE REG. is used for fine adjustment, during shortwave tuning. It is important to remember that the amount of regeneration varies when station frequency is changed, and FINE REG. must be readjusted to maintain regeneration.

AUDIO AND POWER AMPLIFIER:

V-2, the 6AW8A dual tube, combines these two functions. The audio amplifier section increases signal voltage to make it large enough to drive the power amplifier section. The audio power is then delivered to the speaker or PHONES. The amount of signal is controlled by R-10, the VOLUME control used for private listening (phones).

POWER SUPPLY:

The power supply is AC operated (transformer powered) for greater safety and circuit efficiency.

HOW TO USE YOUR SPAN MASTER

- See Figure 12. Connect a single wire antenna to the terminal stamped "A" on the back panel. A good antenna is all important. In some areas reception can be improved by connecting a ground wire to terminal "G". Connect the other end of the ground wire to a water pipe or ground rod.
- Plug the line cord into an outlet supplying 110-125 volts, 50-60 cycles AC ONLY. DO NOT ATTEMPT TO OPERATE FROM DC POWER.

BAND A (STANDARD BROADCAST)

- Turn BAND SWITCH to A, OFF-VOLUME to the middle of its range, and BANDSPREAD all the way to the right. Set the Main Tuning Dial to the desired station on Band A. Be sure SPEAKER-PHONES switch on the back is set to SPEAKER, unless you are using phones.
- Gradually turn REGENERATION to the right until a rushing sound or a whistle is heard. Stop here. This is the most sensitive point, where the receiver has just begun to oscillate (regenerate).
- Slowly turn the Main Tuning dial to the right or left as needed, to make the whistle lower in pitch, until a very low-pitched sound is heard.
- VERY SLOWLY, turn REGENERATION control to the left until the whistle just disappears and the station is clearly heard. Adjust VOLUME for comfortable listening.
- Turn receiver OFF when you are through using it.

BANDS B, C, OR D (SHORTWAVE)

The main difference between standard broadcast and shortwave tuning is that the full sensitivity of the receiver is needed to tune in distant shortwave stations. This is achieved by careful setting of the REGENERATION and FINE REG. controls. Tuning is also more critical on shortwave bands and fine tuning must be done with the BANDSPREAD. A GOOD ANTENNA IS A MUST FOR SHORTWAVE RECEPTION.

- Turn OFF-VOLUME all the way to the right, BAND SWITCH to desired band, BANDSPREAD at 5, FINE REG. at the middle of its range and MAIN TUNING to the desired range of stations.
- Turn REGENERATION slowly to the right until a rushing sound is heard. This is the desired setting. You can check the correctness of this setting by turning the BANDSPREAD through its range — a sound of "birdies" should be heard. If instead of "birdies" you hear a constant whistle, REGENERATION has been turned too far and should be turned back to the left, slightly. Leave BANDSPREAD at 5.
- Tune in the desired station as well as possible with the MAIN TUNING.
- Tune station in clearly with the BANDSPREAD, trying either to the right or left of 5.
- If necessary adjust FINE REG. for better reception.

TUNING ACROSS SHORTWAVE BANDS

Turn Main Tuning to the desired station, BANDSPREAD to 5. If the set sounds dead (no rushing or whistling sound) turn FINE REG. to the right. If there is too much regeneration (constant whistle as you tune the band) turn FINE REG. to the left until the whistle just disappears. For code reception set FINE REG. at the point where the whistle just begins. Tune the station in clearly with the BANDSPREAD.

SERVICING HINTS

If the tubes fail to light, or the receiver sounds "dead", turn the set off and remove the line cord from the power outlet. Take the receiver out of the cabinet and carefully inspect all wiring for correct connection and good solder joints. Most cases of kits failing to operate are caused by a wiring error or poor soldering. Especially check all soldering to ground points, such as solder lugs and the heavy bare wire.

If the receiver operates on some bands, but not all bands, check the wiring to the band coil for each inoperative band. Terminals on S-1, the BAND SWITCH, must not be accidentally shorted together by bare wires or lumps of solder.

WHEN TO LISTEN

Under normal conditions, with patience and practice, it's possible to hear stations from all over the world in a single evening—at times even within a few minutes! All you need is your Span Master, a simple antenna, a knowledge of where and when to listen—plus persistence.

Short-wave broadcasts enable you to learn first-hand what people in other countries have to say about current affairs, and what kinds of music and other entertainment they have. Many programs are broadcast in English for those who know no foreign language, and in the various local languages for those who want to study languages as they are actually spoken in their respective countries.

Some short-wave enthusiasts are interested in receiving QSL's (verification cards or certificates) from the stations to which they have listened. Others report their results to radio clubs; they get their big thrill from seeing their names in print credited with a fine "catch", such as a "first heard" on a new station.

Short-wave radio transmitters include land communications stations, maritime stations, aeronautical stations, amateur (ham) stations, broadcasting stations, police, fire and weather station reports.

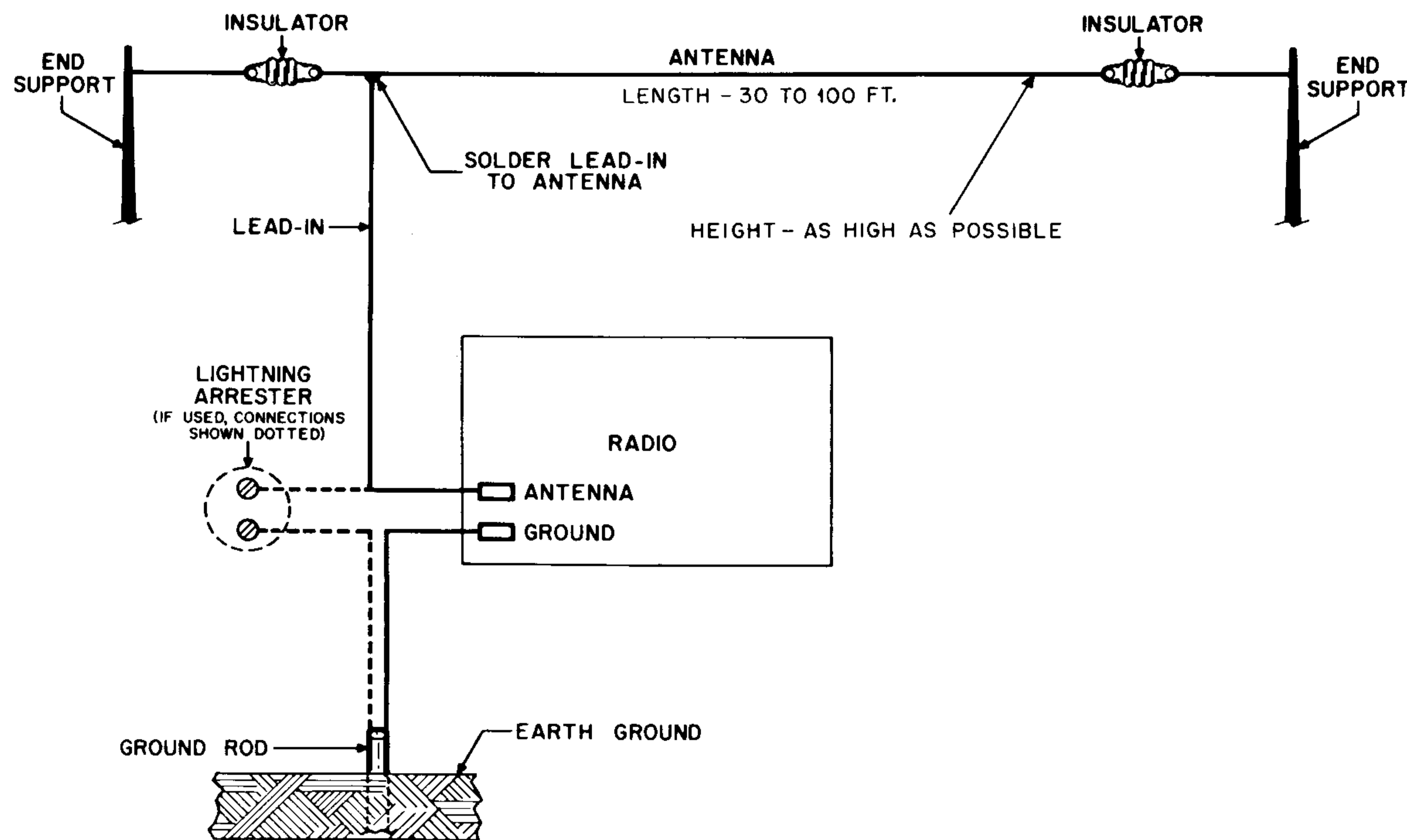

FIGURE 12. HOW TO INSTALL AN OUTDOOR ANTENNA

The Main Tuning dial on your receiver is calibrated (marked) in megacycles (mc). A megacycle is 1000 kilocycles (kc). Calibrations are correct when the BANDSPREAD is in the fully clockwise position. Short-wave stations operate in these megacycle bands—5.95 to 6.20 mc; 7.0 to 7.3 mc amateur band; 9.5 to 9.8 mc; 11.7 to 12.0 mc; 14.0 to 14.3 mc amateur band; 15.10 to 15.45 mc; 17.5 to 17.7 mc and 28.0 to 29.7 mc amateur band.

Amateur bands are often referred to by wavelength (meters) rather than frequency (megacycles). The Main Tuning dial is clearly marked for these amateur bands:

METERS	MC	BAND SWITCH POSITION
80	3.5 to 4.0	B
40	7.0 to 7.3	C
20	14.0 to 14.3	D
10	28.0 to 29.7	D

Reception conditions on each of the short-wave broadcast bands vary a lot at different times of the day and night, and also at different seasons of the year. It's important that you learn when to listen on each band.

In general, for Short Wave Listeners in North America, the best reception on each of these bands during the fall and spring months should be:

The 6 MC band—Evening for Latin America and Europe.

The 7 MC band—Late afternoon and evening for Europe. Evening and early morning for amateur stations.

The 9 MC band—Morning (6 to 8 a.m. your local time) for Asia and Australia; afternoon for Europe and Africa; evening for Europe and Latin America.

The 11 MC band—Morning (6 to 9 a.m. your local time) for Asia and Australia; afternoon for Europe and Africa; evening for Latin America.

The 14 MC band—late morning and afternoon for amateur stations.

The 15 MC band—Morning and afternoon for Europe and North America; evening for North and South America.

During the winter months, the best bands for evening reception are lower than during the fall and spring. For instance, the 9 MC band becomes poor for reception from Europe during the evening hours, and the 6 MC band becomes the best band for European reception.

In the summer months, the best evening reception shifts to the higher bands. Evening reception from Europe becomes good in the 11 MC band, although the 9 MC band remains good for reception from that area.

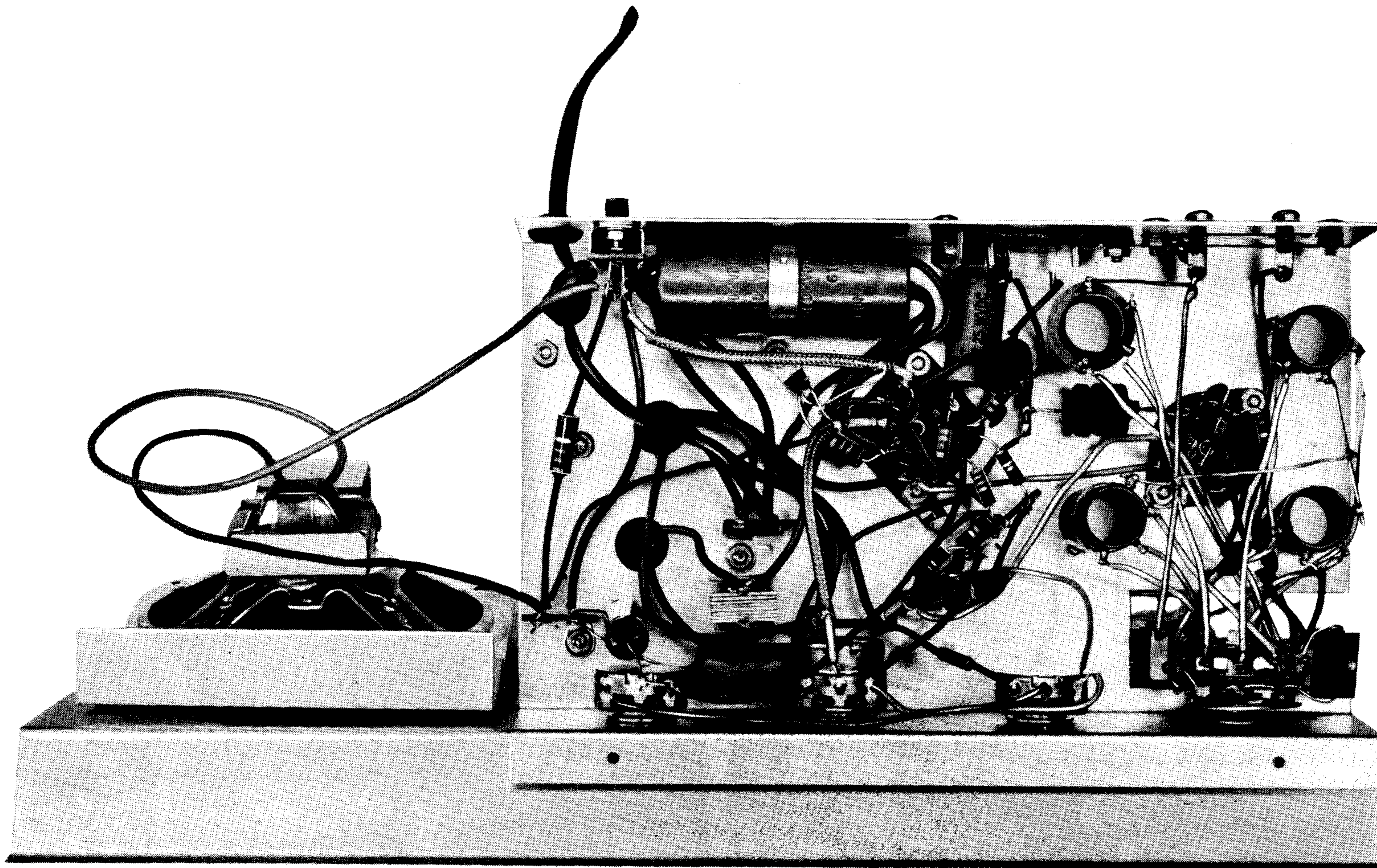

RESISTANCE CHART

TUBE	PIN								
	1	2	3	4	5	6	7	8	9
V-1, 6BZ6	2.2M	0	0	0.3	2.8K*	2.2K*	0	—	—
V-2, 6AW8A	3.3K	470K	47K*	0	0.3	270	1M	0*	1.5K*

Readings taken from point indicated to chassis ground, except * measured with respect to terminal 6 of TS-2.

PARTS LIST

Symbol No.	Description	Part No.
CAPACITORS		
C-1	MAIN TUNING	281014
C-2	BANDSPREAD	281013
C-3	450 $\mu\mu$ fd mica	266458
C-4	100 $\mu\mu$ fd mica	266017
C-5	.001 μ fd disc	276016
C-6	15 $\mu\mu$ fd disc	277159
C-7	.001 μ fd disc	276016
C-8	.1 μ fd tubular	243014
C-9	8 μ fd, 150 v. electrolytic	293010
C-10	.005 μ fd disc	276054
C-11	330 $\mu\mu$ fd disc	276338
C-12	330 $\mu\mu$ fd disc	276338
C-13	10 μ fd, 25 v. electrolytic	201100
C-14	.005 μ fd disc	276054
C-15	330 $\mu\mu$ fd disc	276338
C-16	.02 μ fd disc	276025
C-17	30-30 μ fd, 175 v.; 20 μ fd, 25 v. electrolytic	213304

Symbol No.	Description	Part No.
COILS		
L-1	Band A coil	111301
L-2	Band B coil	111302
L-3	Band C coil	111303
L-4	Band D coil	111304
L-5	RF choke, 5 mh	161001
L-6	Filter choke, 5.5 hy, 50 ma	140003

Symbol No.	Description	Part No.
RECTIFIER		
CR-1	Selenium rectifier, 50 ma	620001

Symbol No.	Description	Part No.
RESISTORS		
All are 10% tolerance, 1/2 watt resistors, unless otherwise specified.		
R-1	2.2 meg Ω	301225
R-2	10K Ω FINE REG. control	390139
R-3	50K Ω REGENERATION control	390140
R-4	22K Ω	301223
R-5	10K Ω	301103
R-6	18K Ω	301183
R-7	100K Ω	301104
R-8	470K Ω	301474
R-9	3,300 Ω	301332
R-10	1 meg Ω VOLUME control with ON-OFF switch, S-3	390020
R-11	47K Ω	301473
R-12	270 Ω , 1 watt	304271
R-13	1500 Ω , 1 watt	304152

Symbol No.	Description	Part No.
SWITCHES		
S-1	2-Wafer BAND SWITCH	432208
S-2	Slide switch	431101
S-3	ON-OFF switch	see R-10

Symbol No.	Description	Part No.
TERMINAL STRIPS		
TS-1	2-terminal; mounting tab at right	440202
TS-2	6-terminal	440601
TS-3	2-terminal; mounting tab at left	440203
TS-4	2-terminal; mounting tab at left	440203
TS-5	2-screw terminal strip	441202

Symbol No.	Description	Part No.
TRANSFORMERS		
T-1	Power transformer	101301
T-2	Output transformer	see Speaker

Symbol No.	Description	Part No.
TUBES		
V-1	6BZ6	610050
V-2	6AW8A	611026

Description	Quan.	Part No.
MISCELLANEOUS		
Cabinet	1	702007
Chassis	1	461333
Decal, "K"	1	724007
Dial, BANDSPREAD	1	725001
Dial, MAIN TUNING	1	725000
Dial plates, for mounting dials	2	764523
Grommets, rubber, large	4	830200
Grommets, rubber, small	2	830001
Jack, for PHONES	1	502227
Knobs, large, with plastic skirts	2	764522
Knob, small, for flatted shaft	1	764525
Knob, small, for split knurled shaft	3	764524
Panel Assembly	1	040053
Includes:		
Panel	1	462812
Perforated grill	1	850047
Speaker, with output transformer, T-2,	1	730003
Tube socket, 7-pin	1	501070
Tube socket, 9-pin	1	501090

Description	Quan.	Part No.
WIRE, SOLDER AND SPAGHETTI		
Bare wire, heavy, 10"	1	806610
Bare wire, thin, 20"	1	806020
Insulated wire, solid:		
2", red	3	801002
3", orange	4	801003
4", yellow	1	801004
5", green	3	801005
6", blue	1	801006
Insulated wire, stranded:		
3 1/2", white-black	1	804093
4 1/8", white-black	2	804092
4 1/4", white-red	3	804091
2 1/4", white-yellow	3	804090
2 1/2", white-green	2	804094
Line cord	1	802001
Shielded wire, 8"	1	803028
Solder, 40"	1	930002
Spaghetti, 30"	1	812012

Description	Quan.	Part No.
HARDWARE		
Flat washer, 25/64"	4	580702
Lockwasher, #4	2	582200
Lockwasher, #6	22	582300
Lockwasher, 3/8"	4	582700
Mounting bracket for speaker	1	470159
Mounting clip, with nut	2	531007
Nut, #4-36	2	570230
Nut, #6-32	26	570340
Nut, 3/8-32	4	570840
Screw, machine:		
#4-36x1/4"	2	560232
#6-32x1/8"	8	560340
#6-32x5/16"	18	560343
#8-32x3/8"	1	564345
#10-32x3/8"	2	564344
Screw, self-tapping:		
#6x5/16", round head	2	562393
#6x3/8", flathead	4	564343
Solder lug	6	553005
Tinnerman bracket	1	531006

SUGGESTED TOOLS AND ACCESSORIES		
Allied Stock No.	Description	Price *
46N852	Soldering iron	\$5.26
50N132	6" long-nose pliers	1.54
50N133	5" diagonal cutters	1.34
45N796	6" screwdriver	.72
83Y100	Antenna kit	1.03
59J110	Headphones	2.00

* Prices subject to change.

V-1
6BZ6
DETECTOR

V-2A
1/2-6AW8A
AUDIO AMPLIFIER

V-2B
1/2-6AW8A
POWER AMPLIFIER

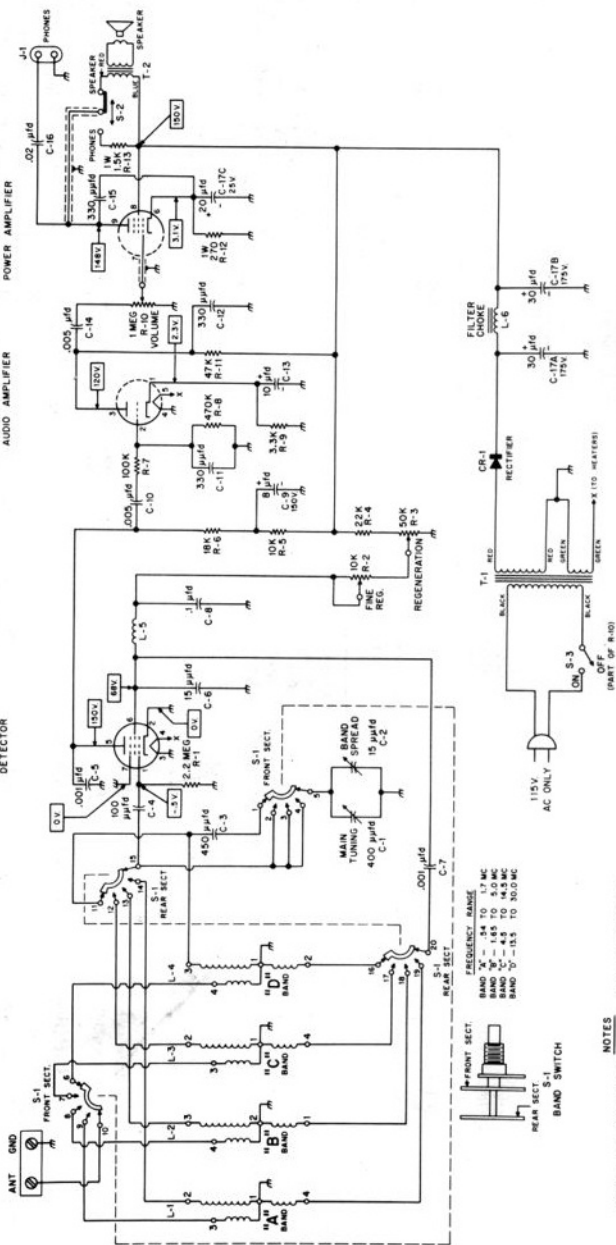

FREQUENCY RANGE
 BAND "X" - .54 TO 1.7 MC
 BAND "Y" - 1.85 TO 3.5 MC
 BAND "Z" - 4.5 TO 30.5 MC

CAPACITORS INDICATED IN OHMS
 UNLESS OTHERWISE SPECIFIED.

RESISTORS INDICATED IN OHMS
 UNLESS OTHERWISE SPECIFIED.

MEASUREMENTS MADE WITH A VTVM

FIGURE 13. SCHEMATIC DIAGRAM

K4XL's **BAMA**

This manual is provided **FREE OF CHARGE** from the “BoatAnchor Manual Archive” as a service to the Boatanchor community.

It was uploaded by someone who wanted to help you repair and maintain your equipment.

If you paid anyone other than BAMA for this manual, you paid someone who is making a profit from the free labor of others without asking their permission.

You may pass on copies of this manual to anyone who needs it. But do it without charge.

Thousands of files are available without charge from BAMA. Visit us at <http://bama.sbc.edu>